

## **Beamline practice at BL01B1 (XAFS)**

ver. 2008/09/19 H. Tanida, T. Uruga (JASRI)

### **1. Introduction**

The bending magnet beamline, BL01B1, is used for various applications of XAFS over a wide energy range from 3.8 to 113 keV. In the practical training course, we plan to show how to measure XAFS of dilute samples or thin films, which covers alignment of x-ray optics, alignment of sample position, and adjustment of a 19-element Ge solid-state detector (SSD). We will also demonstrate Quick XAFS measurement in transmission mode.

### **2. Plan of practice**

- 9:00-** Introduction of beamline, alignment of optics, measurement system and major scientific activities at BL01B1.
- 9:30-** Planning of experimental set up for samples to be measured.
- 10:00-** Alignment of the x-ray optics.
- 11:00-** Setup of the measurement system for Quick XAFS in transmission mode.
- 11:30-** X-ray energy calibration using standard sample.
- 12:00-** Measurement of Quick XAFS spectra of samples, including some participants' samples.
- 12:30-** ----- Lunch -----
- 13:30-** Introduction of 19-element Ge-SSD system for fluorescence mode XAFS measurement of dilute and thin film samples.
- 14:00-** Setup of 19-element Ge-SSD.
- 15:00-** Measurement of XAFS spectra of dilute samples or thin film samples.  
During the measurement, data treatment and preliminary analysis of XAFS spectra.
- 16:30-** Discussion on some technical and scientific subject.
- 17:00** Close.

### 3. Alignment of x-ray optics and experimental stage

- Figure 1 shows schematic layout of BL01B1.
- Main operation in alignment of x-ray optics is follows.
  - Switch of diffraction plane of monochromator crystals between Si(111), Si(311) and Si(511) to cover energy range for XAFS measurements.
  - Change of glancing angle of mirror to remove higher-harmonic x-rays.
- Above operation slightly changes beam height downstream of monochromator.
- Fine adjustment of slits and mirrors in the optics hutch is done by measuring x-ray intensity using 1st ionization chamber in the experimental hutch (Fig. 2).
- The height of experimental stage in the experimental hutch is adjusted to x-ray beam by scanning in vertical direction.
- Fixed beam condition is achieved by adjusting the rotation angle of 1st crystal of monochromator around beam axis to 2nd crystal.
- The control program for operation of x-ray optics realizes following x-ray beam.
  - Quite low contamination ( $<10^{-5}$ ) of higher harmonics.
  - Fixed beam position during XAFS scans passing through the center of slits in the experimental hutch.
  - Focused beam in vertical direction (0.1-0.2 mm).
- In the BL practice, the participants will align the optics following the manual upped on the WEB site, <http://bl01b1.spring8.or.jp/BL01B1opticsmanEng040213.html>.

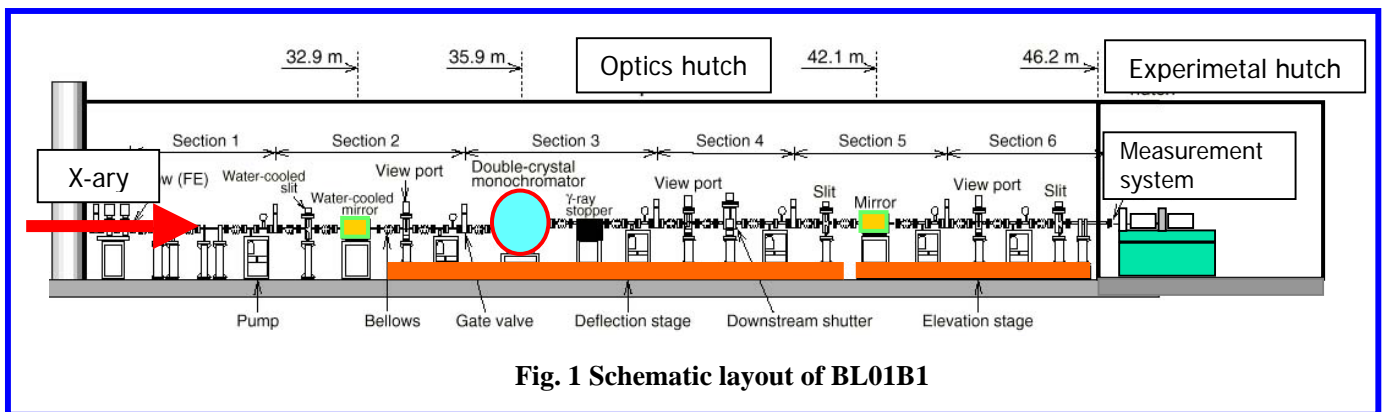

#### 4. Quick XAFS measurement in transmission mode

- Quick XAFS measurement is realized by data storage of x-ray detector output signals and Bragg angles of monochromator in each memory board during continuous scanning.
- The arrangement and control system for transmission mode Quick XAFS measurements are shown in Figs. 2 and 3.
- Setup the ionization chambers.
  - Select and flow adequate gases for ionization chamber.
  - Gases are selected to have the following absorption ratio of incident x-rays; 10-30 % for IO chamber and 70-90 % for I chamber, respectively.
  - Gases are listed in the WEB site, <http://bl01b1.spring8.or.jp/RatioIO.html> and <http://bl01b1.spring8.or.jp/RatioI1.html>.
- Setup of measurement system
  - Set the beam size incident on the sample by slit opening.
  - Set the gain of current amplifiers (Amp) for each ionization chamber.
- Operation of program of QXAFS measurement
  - Set the following parameters in the operation program
    - ◇ Energy range and step for a XAFS spectrum
    - ◇ Total measurement time for a XAFS spectrum.

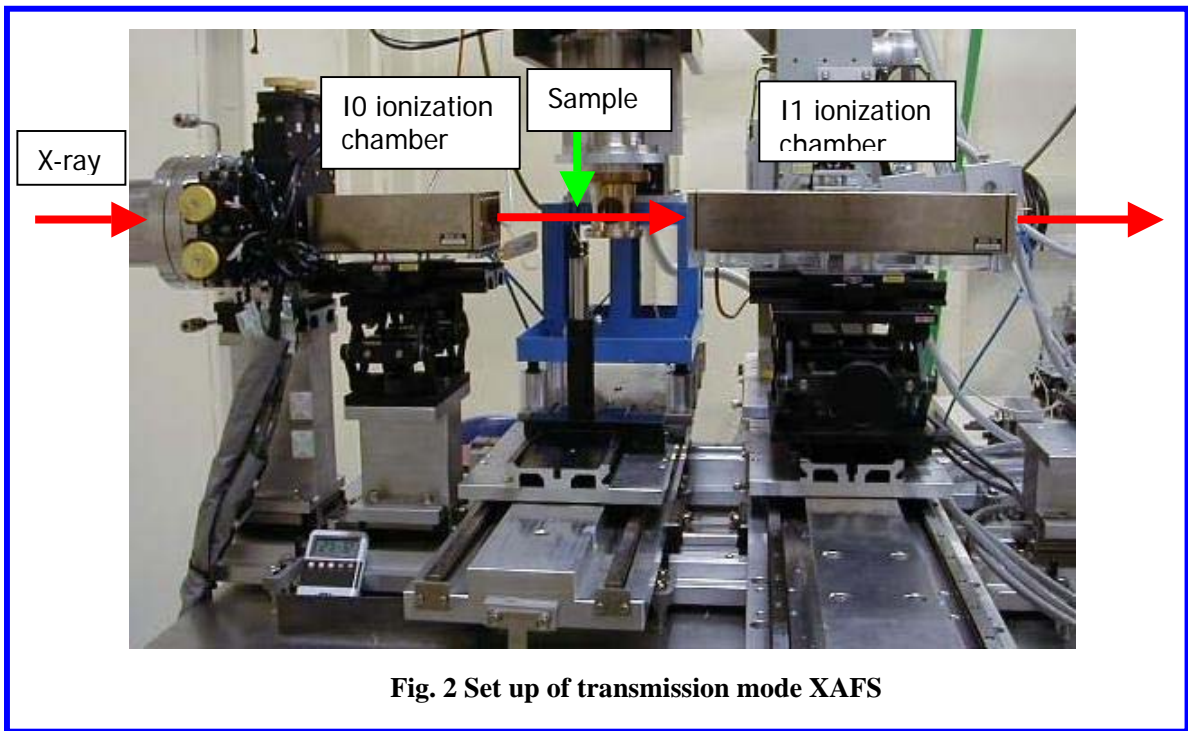

Fig. 2 Set up of transmission mode XAFS

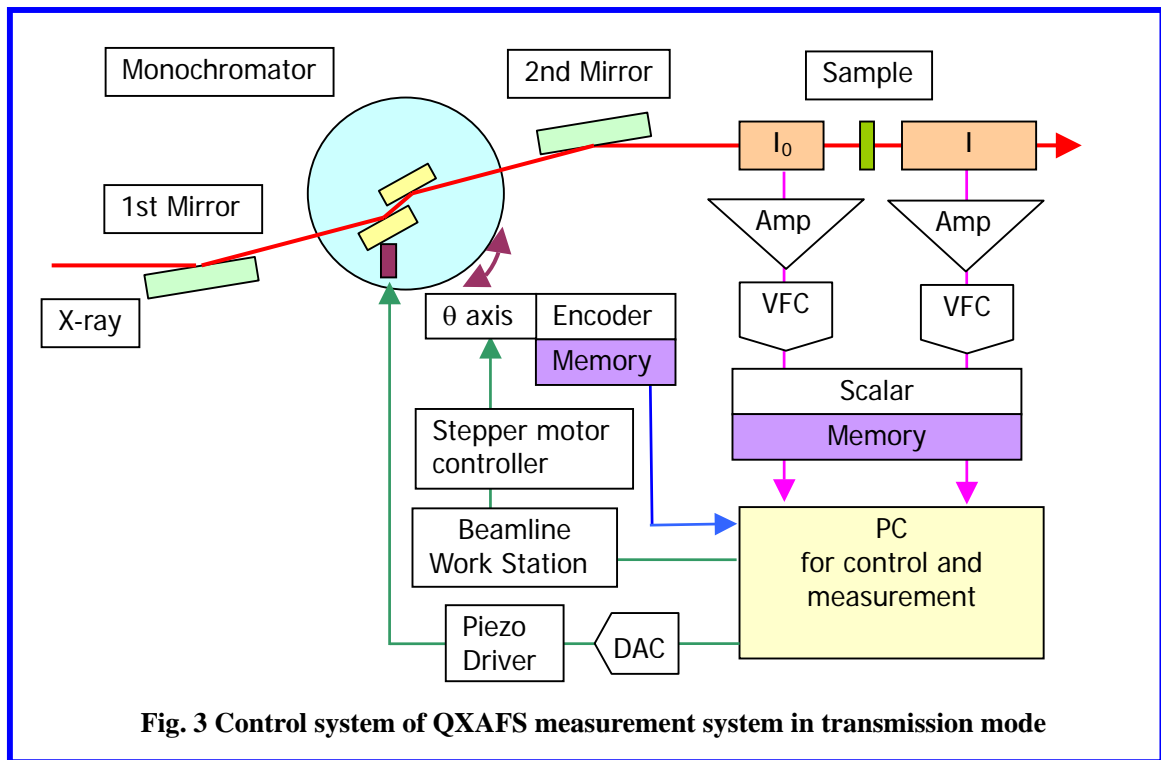
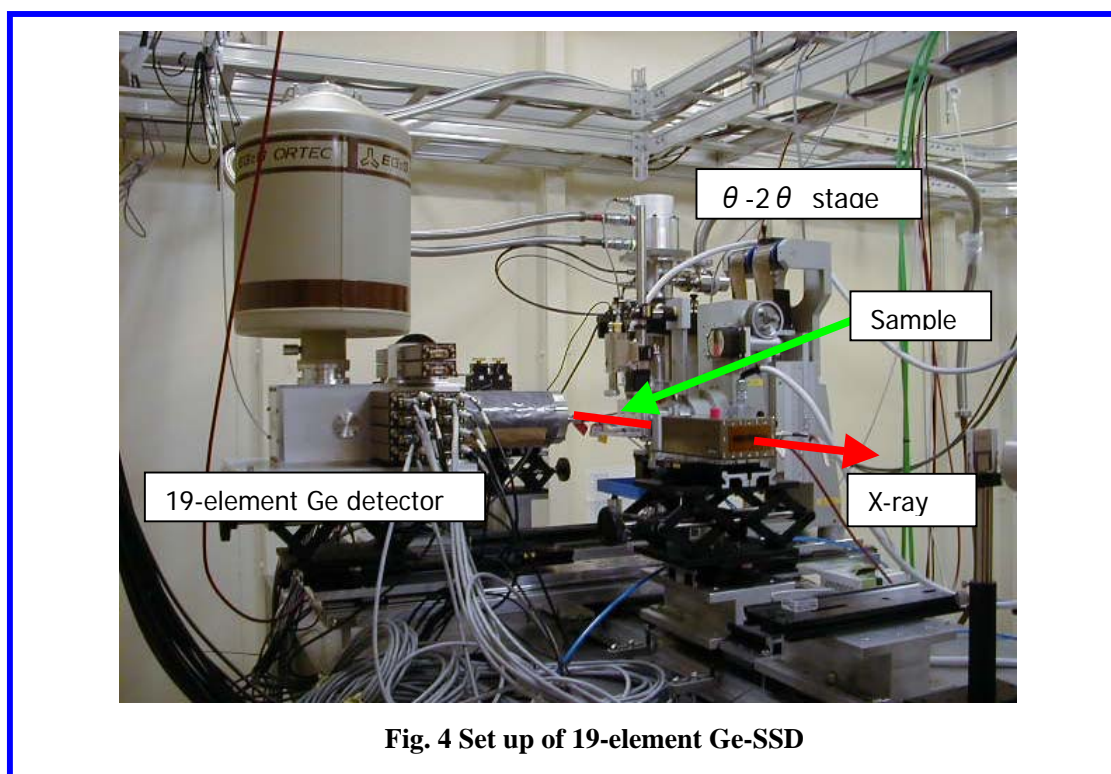

Fig. 3 Control system of QXAFS measurement system in transmission mode

## 5. Measurement of fluorescence mode XAFS spectra by 19-element Ge SSD

### 5.1 Setup of 19-element SSD

- The measurement system consists of 19-element SSD and digital x-ray pulse-processor (XMAP; <http://www.xia.com/DXP-XMAP.html>).
  - XMAP is used for processing the output signal of SSD preamplifier, such as signal pulse amplification and energy spectrum analysis.
- Cooling of detector unit.
  - Fill the dewar of Ge SSD with liquid N<sub>2</sub> to achieve high energy resolution.
  - Pre-cooling will be done by BL staff more than 12 hr before use.
- Supply power to the SSD preamplifier
- Supply high voltage (-1 kV) in small steps to avoid damage to the SSD.



## 5.2 Set of energy window of SSD

- Energy window of SSD should be tuned to the fluorescence x-rays from the target element in the sample.
  - xMAP is operated from PC with control software, xManager.
- Set standard sample.
- Control of xManager
  - Adjust the parameters of xManager to get energy spectra for each element of SSD.
    - ✧ Parameters are energy range, threshold energy, and peaking time (shaping time).
    - ✧ Eliminate elements does not work well.
  - Do gain matching and set energy window of SCA
- Set target sample.
- **Caution:** high x-ray photon flux incident on the SSD makes damages to SSD element.
  - Adjust the slit opening and/or distance between the sample and SSD to achieve the x-ray photon flux of around  $10^5$  cps per element of SSD.

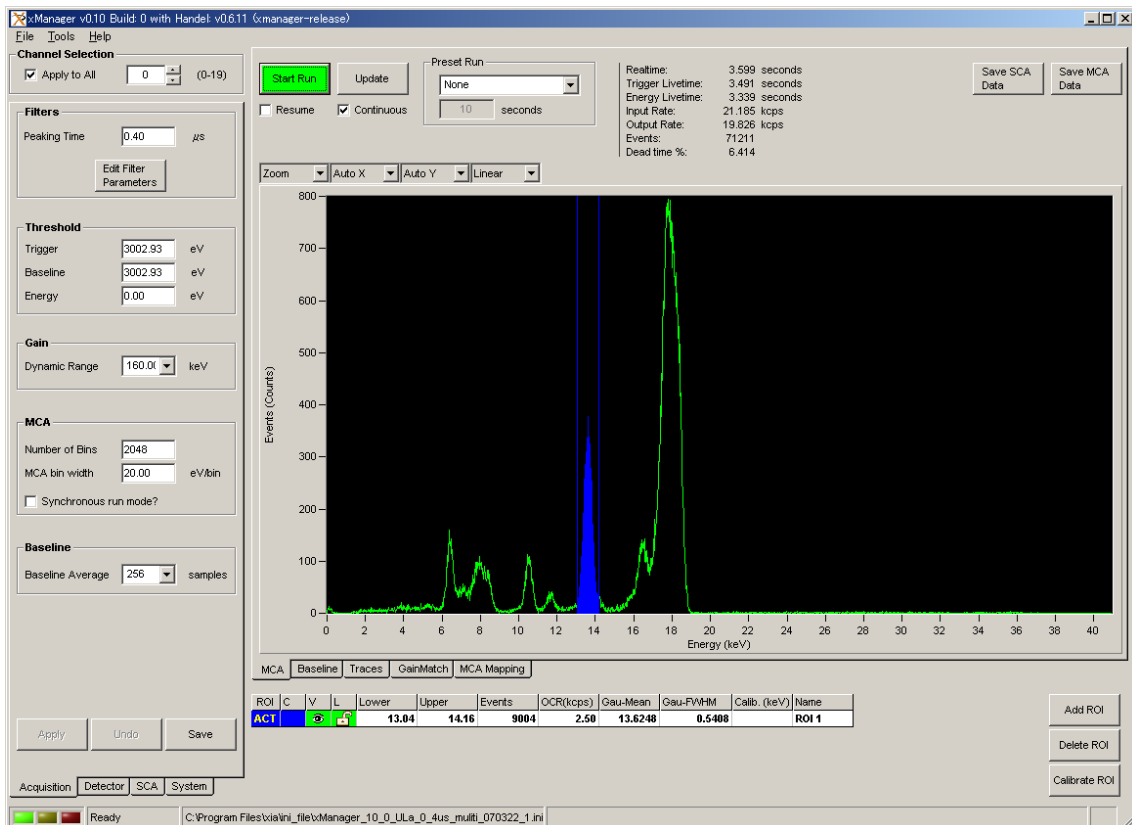

Fig. 5 Screen shot of xManager

### 5.3 XAFS measurement of thin film sample

- Set sample and equipments
  - Mount thin film sample on  $\theta$ - $2\theta$  stage in glancing angle geometry.
  - Set solar slit and filter for scattered x-ray absorption between sample and SSD if quality of XAFS spectrum improves.
- Adjust sample position
  - First, set the glancing angle of the thin film at around 2 degree.
  - Adjust the vertical position of the thin film by monitoring fluorescence x-ray intensity during vertical scanning.
- Run step-scan XAFS measurement program
  - Select mode of continuous in-plane rotation of thin film to remove diffraction spikes in XAFS spectra in the case of single crystalline sample.

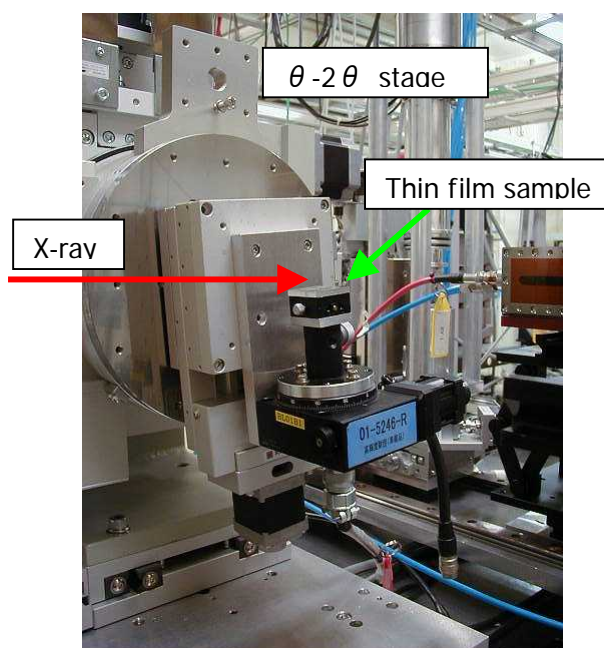

Fig. 6 Set up of thin film sample